



SST1510 DP Differential Pressure Transmitter For High Pressure, Deepwater Applications

**Solartron ISA – High performance
instruments for the life of your reservoir**

Engineering Excellence for Long-term Performance

Operating subsea to depths of 5,000 ft (1500 m) and high process pressures up to 10,000 psi (690 bar), the SST1510 DP is one of the most accurate and stable deepwater differential pressure transmitters on the market. Its unique silicon crystal sensor technology provides high accuracy and long-term measurement stability.

Solartron ISA's SST family sets the global performance standard for subsea measurement instrumentation in the oil and gas industry. Used by leading exploration companies, SST products have an unsurpassed service history in the field, even in the most demanding and hostile installation environments.

Highly Stable, Accurate Measurement

Solartron's 40 years of flow measurement experience has made us experts in pressure measurement technology. For subsea applications, only the best pressure measurement technologies should be employed. This is especially critical if the pressure measurement will be used for flow calculations, as long-term inaccuracy can lead to significant fiscal errors.

The SST1510 DP is equipped with the Yokogawa innovative silicon crystal technology which has proven more accurate and more stable than competitive technologies. In fact, the technology is four times more sensitive than traditional piezo-resistive sensor technology used in competitive products.

Robust Construction

Small and light, yet built for long-term use in the hostile deep subsea environment, the SST1510 DP integrates a fully machined sensor body and pressure flanges with high strength bolts and nuts. The electronics enclosure can be fitted with a variety of subsea electrical connectors or penetrators to suit client/project requirements. Every unit is hyperbarically tested to 1500 m water depth prior to dispatch, proving the integrity of the twin O-ring sealing arrangement.

Comprehensive Qualification Testing

Every one of Solartron's subsea devices is fully tested to rigorous standards appropriate to the harsh subsea environment including: hyperbaric, electrical, EMC, shock/vibration, temperature soak and cycling. The Solartron name is your assurance that the instrument meets or exceeds the highest international standards.

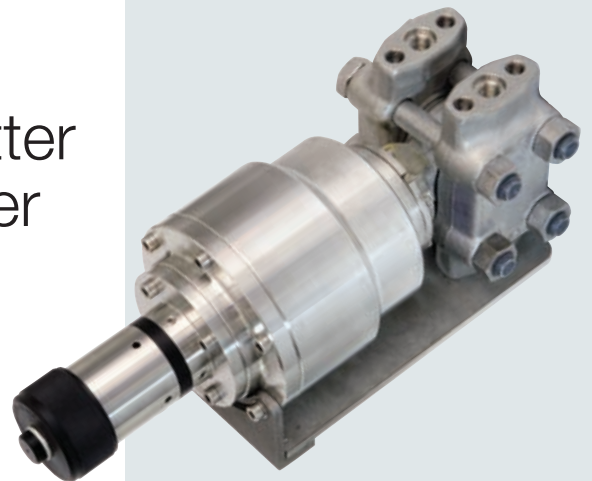

Key Specifications

- ✓ Depth 5,000 ft (1500 m)
- ✓ Pressure 10,000 psi (690 bar)
- ✓ Accurate to $\pm 0.065\%$ of span
- ✓ Stability $\pm 0.1\%$ of upper range limit / 5 years

Features

- ✓ 4 – 20 mA
- ✓ HART
- ✓ CANopen (Hi-Speed and Lo-Speed)
- ✓ Modbus (RS485)
- ✓ Foundation Fieldbus

Qualifications

- ✓ API 6A / ISO 10423
- ✓ ASME IX
- ✓ ISO 13628-6
- ✓ IEC 61000-4
- ✓ ISO 9001

Hackworth Industrial Park, Shildon, County Durham, UK DL4 1LH • Tel: +44 (0)1388 773065 • Fax: +44 (0)1388 774888

e-mail: sales.solartronisa@ametec.com • www.solartronisa.com

© 2008, by AMETEK, Inc. All rights reserved.

AMETEK[®]
SOLARTRON ISA

SST1510 DP Differential Pressure Transmitter For High Pressure, Deepwater Applications

Specifications

PERFORMANCE SPECIFICATIONS

Transmitter output

4-20 mA, HART, Modbus (RS485), CANopen (Hi-Speed and Lo-Speed), Foundation Fieldbus

Accuracy

Reference accuracy of calibrated span (including the effects of zero-based linearity, hysteresis, and repeatability): $\pm 0.065\%$ of span

For spans below X: $\pm (0.015 + 0.05 X/\text{span}) \%$ of span

Where X equals:

Capsule	mbar
M	100 (40 inWG)
H	1000 (400 inWG)

Temperature

Total ambient temperature effects per 50°F (28°C) change

Capsule Effect

M: $\pm [0.07\% \text{ span} + 0.02\% \text{ URL}]$

H: $\pm [0.07\% \text{ span} + 0.015\% \text{ URL}]$

Pressure

Total static pressure effects per change $\pm [0.1\% \text{ span} + 0.028\% \text{ URL}]$ per 1000 psi (69 bar)

Effect on zero (can be corrected at line pressure) $\pm 0.028\%$ of URL per 1000 psi (69 bar)

Stability

$\pm 0.1\%$ of URL per 60 months

Power supply effects

$\pm 0.005\%$ per volt: (from 21.6 to 32 VDC, 350 Ω)

Calibration

High static line pressure calibration optional

Operating temperature calibration optional

FUNCTIONAL SPECIFICATIONS

Ambient temperature limits

-22 to 176°F (-30 to +80°C)

Process temperature limits

-40 to 248°F (-40 to 120°C)

Working pressure limits (silicone oil)

Maximum working pressure limit 10,000 psi (690 bar)

Maximum test pressure limit 15,000 psi (1035 bar)

INSTALLATION

Supply voltage

10.5 to 42 VDC for analog operation

16.4 to 42 VDC for digital communications

Load

0 to 1335 Ω for analog operation

250 to 600 Ω for digital communication

SPAN AND RANGE LIMITS

Measurement span and range

	mbar	in WG
M		
Span	10 to 1000	-1000 to 1000
Range	4 to 400	-400 to 400
H		
Range	50 to 5000	-5000 to 5000
Span	20 to 2000	-2000 to 2000

PHYSICAL SPECIFICATIONS

Dimensions

Unit height (excluding electrical connection): 9-5/8" / 245 mm

Unit width: 6" / 150 mm

Unit weight: 29.7 lbs (13.5Kg)

Process connections: Traditional flanges

Physical support: Direct mount using 7/16" UNF bolts

Wetted parts materials

Diaphragm: Hastelloy C-276

Cover flanges: Stainless steel 316

Capsule gasket: Teflon coated stainless steel 316L

Vent and plug: Stainless steel 316

Process connector seal ring: PTFE / cobalt spring

Non-wetted parts materials

Bolting: SUS630

Housing: Stainless steel 316

Seal: Viton O-rings complete with PTFE anti-extrusion rings

Dimensions

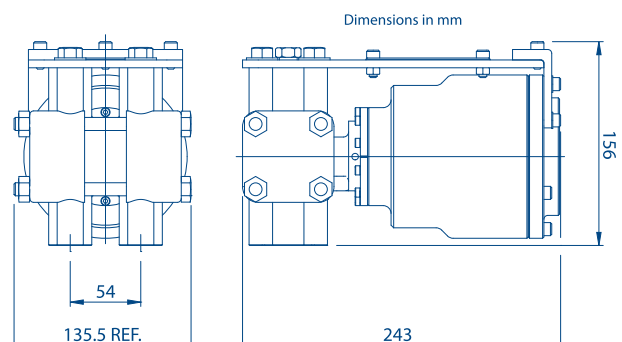

SOLARTRON ISA

Hackworth Industrial Park, Shildon, County Durham, UK DL4 1LH

Tel: +44 (0)1388 773065 • Fax: +44 (0)1388 774888

e-mail: sales.solartronisa@ametech.com • www.solartronisa.com

Houston Sales and Services

4903 W. Sam Houston Parkway, N., Suite A-400, Houston, TX 77041

Tel: +1 713-466-4900 • Fax: +1 713-849-1924